

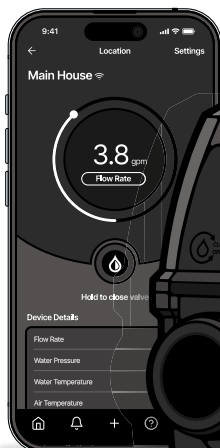

UNITED
Water Softeners



LEAKSECURE

Smart Leak Detection +Automatic Shutoff

Installation + Operation Manual

- + Installation Guide
- + Technical Specifications
- + Manual Shutoff Procedure
- + Homeowner Guide (On-boarding)
- + Bluetooth Mode

ASSEMBLED

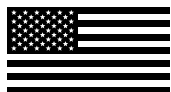

IN USA

CONTROL YOUR WATER[®]



Download
The App:





LEAKSECURE[®]

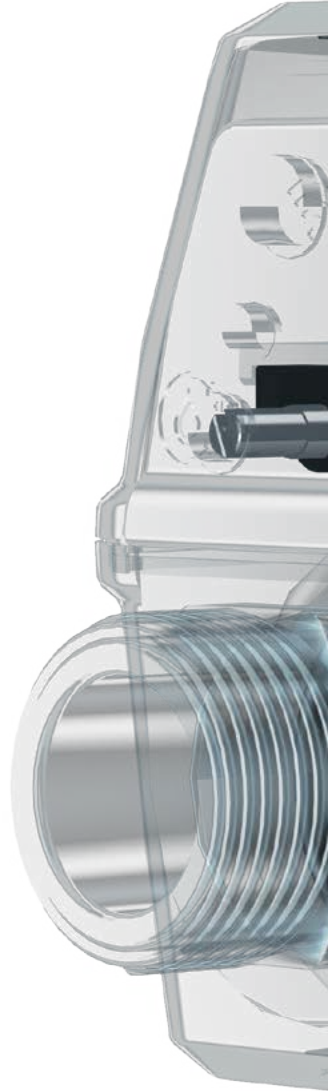

UNITED
Water Softeners

CONTROL YOUR WATER®

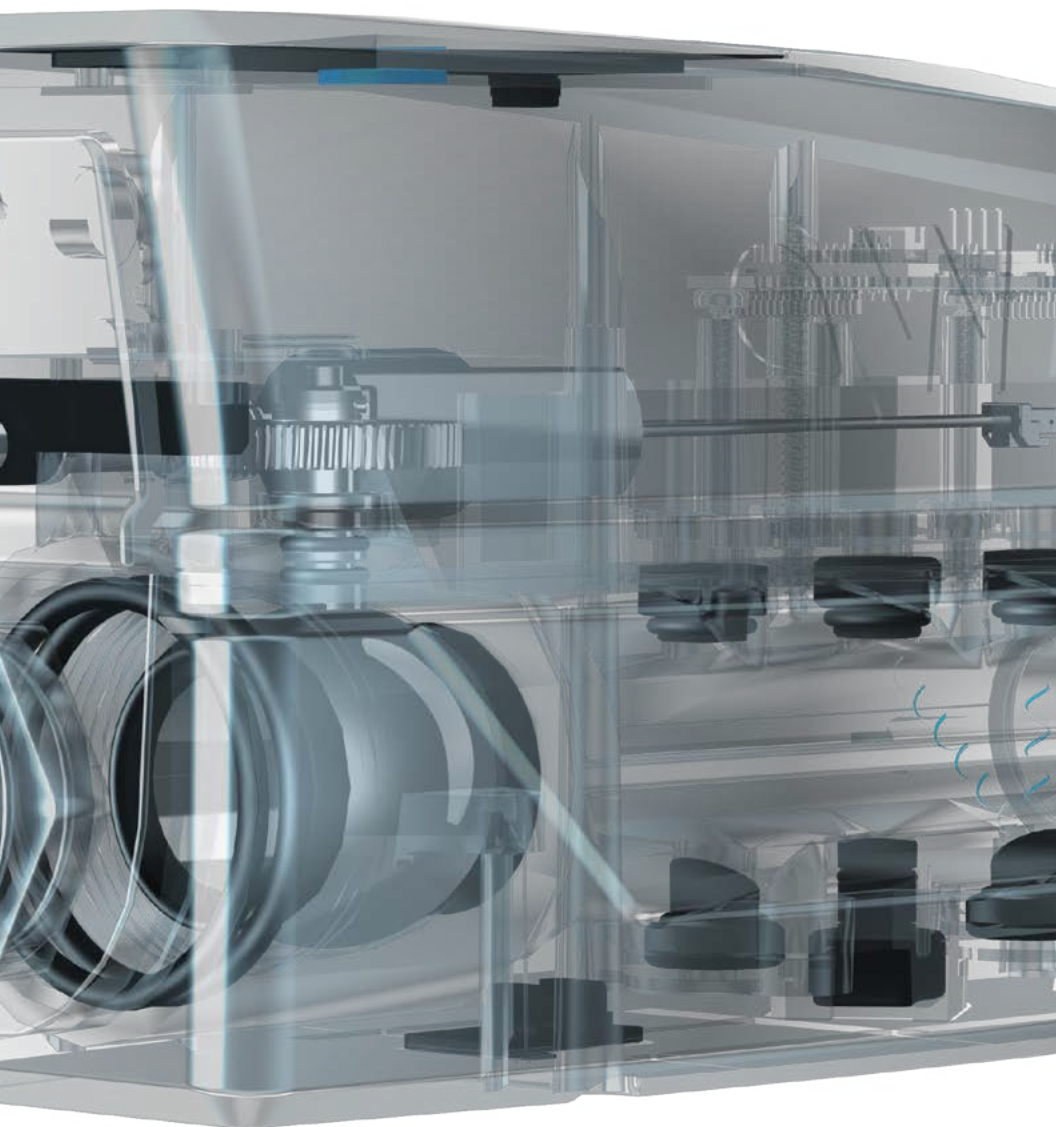
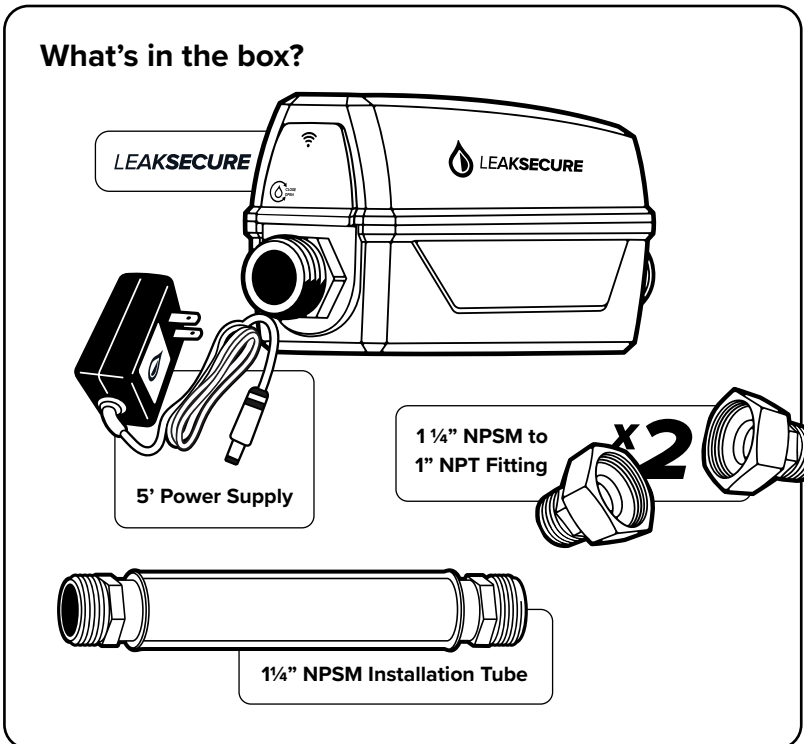
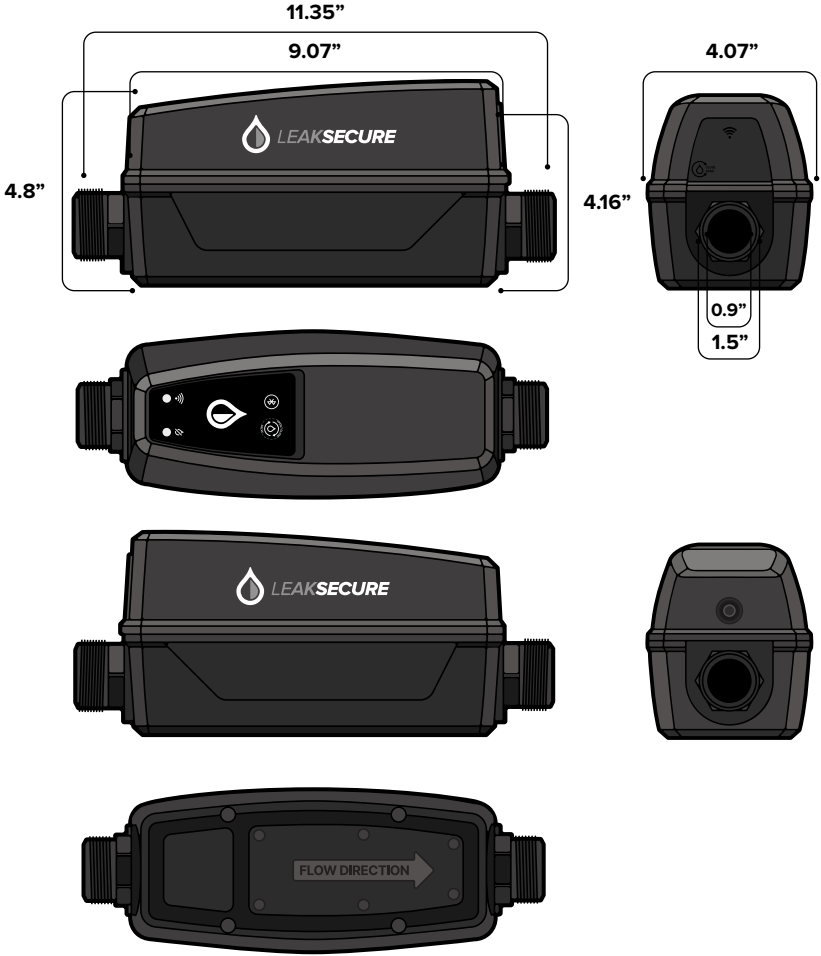

Table Of Contents

Inventory	1
Dimensions/Diagram	2
Installing LeakSecure	3
Manual Shutoff Procedure	5
Technical Specifications	6
Homeowners Guide (On-boarding)	7
Bluetooth Mode	13
Warranty	15
Privacy Policy	17



Dimensions



Pairing Button

Press to set the unit to Pairing Mode



Pairing Light

Green: Connected to Bluetooth or Wi-Fi network
Unlit: Not connected to Bluetooth or Wi-Fi network



Open/Close Button

Press to open or close the valve



Valve Status Light

Green: Valve is open
Red: Valve is closed
Unlit: Unit is not powered

Installing *LEAKSECURE*

Horizontal installation diagram shown. For a vertical installation, rotate this page 90 degrees counter-clockwise.

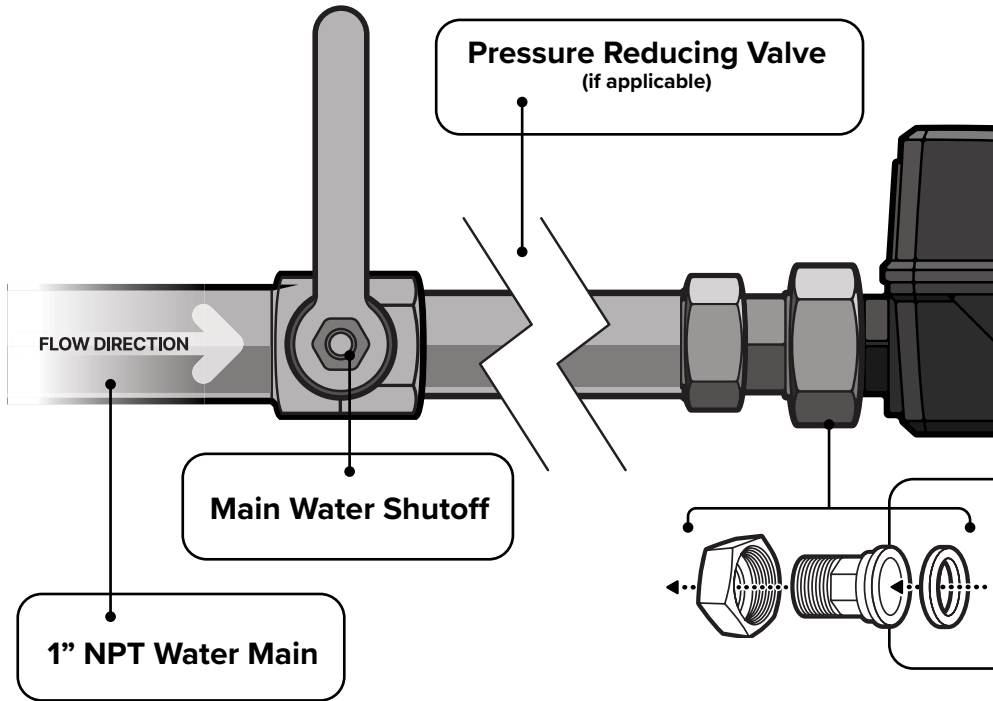

Installation Requirements

- 1** The LeakSecure device is installed in an accessible location on the main cold water supply line from water provider.
- 2** The device must be installed **AFTER** water meter, main water shut-off, and pressure reducing valve (if applicable).
- 5** 110/220V 15W power supply with continuous power within 5' of the installation. A GFCI outlet is recommended.
- 6** A smartphone with the LeakSecure app installed is required to activate your LeakSecure device, receive notifications, and perform remote water shutoff.

IMPORTANT: LeakSecure should be installed by a licensed plumbing professional. Failure to follow installation instructions may lead to an improperly functioning or leaking device and void manufacturer's warranty. See full warranty terms on page 15

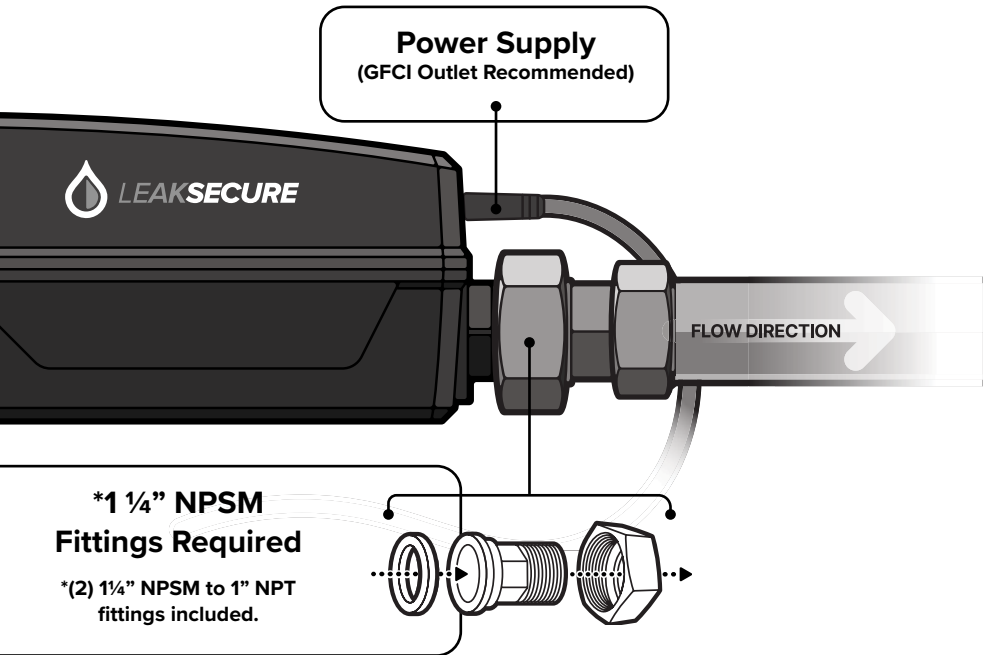

3 For accurate monitoring and water usage data, your device must be installed **BEFORE** water heaters, water softeners, whole house filters, etc.

7 The device must be in range of a Wi-Fi network (WLAN connectivity / IEEE 802.11 bgn, 2.4 GHz range)

4 The power supply and device must not be buried or installed where the ambient temperature can exceed 140 deg F (60 deg C) or below 32 deg F (0 deg C).

Manual Valve Operation

DO NOT USE DRILL MOTOR AS SCREW DRIVER! MANUAL SCREW DRIVER ONLY!

This operation should only be performed in cases of extended power outage and/or when no other option is available. If using the home's valve at the water main will achieve the same desired result, it is preferred to use that option until power is restored.

Step 1:

Determine if valve is OPEN or CLOSED. Since there is no visual indicator of Open/Close status when power is OFF on LeakSecure , the user should turn on a water faucet in the residence and determine if flow is normal or non-existent.

Step 2:

If flow is present at the faucet then there is no need to manually operate the valve. Doing so will just cause problems when power is restored. If shutoff is desired , use meter shutoff instead of the LeakSecure valve if possible.

Step 3:

If flow is not present and is needed 1st Remove rubber cover on one end of unit. Then Use screw driver to turn manual override . Turn CCW until water flow is restored to normal . It should only require 5-7 full turns to restore typical flow but 15 full turns will open the valve completely. Then Replace rubber cover.

Step 4:

When power is restored the LeakSecure unit must be recalibrated for normal operation. This can and should be commanded from the App . Calibration will make 2-3 full turns (2 minutes time) and then leave valve fully open.

Close the valve:

15x
⌚ Clock-wise

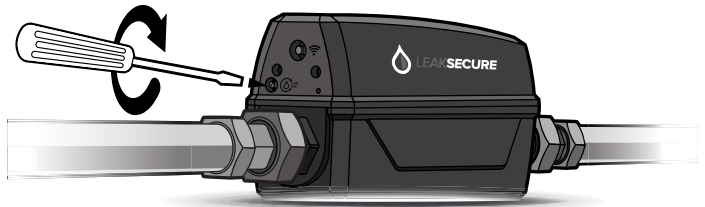

Open the valve:

15x
⌚ Counter Clock-wise

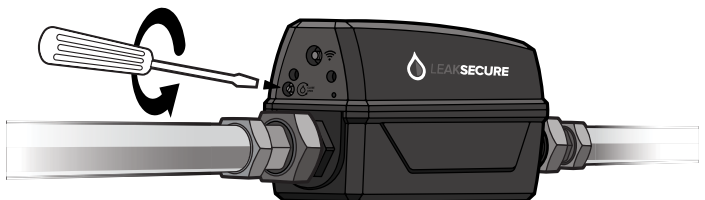

Technical Specifications

Description/Name

LeakSecure

Location

Indoor or Outdoor in an approved enclosure

Orientation

Vertical or horizontal.

Fitting Size

1" male threaded (NPSM) ends designed to adapt to different fittings and plumbing materials (PEX, copper, PVC, etc...)

Compatible with pipe sizes up to 1 1/4"

Note: pipe fitting adapters are not included.

Dimensions + Weight

4.8" L x 4" W x 9" H 11.3"

Weight: 2.85 lbs

Max PSI

125psi

Sensors

Proprietary ultrasonic flow sensor

High definition pressure sensor +/-0.5%

Temperature sensor +/- 5°F

Humidity Sensor

TDS Sensor (Water Quality)

Shut-Off Valve

Stainless steel full bore construction

Electronic for remote control

Manual override with standard slotted screwdriver

Wireless

802.11 b/g/n @2.4Ghz

Antenna

Integrated External antenna

Power

110/220V 15W power supply with continuous power within 5' of the installation.

A GFCI outlet is recommended.

AC Power

Input - 110/220 V AC

Output - 5V/3A DC

Features

Leak alert notifications

Automatic + remote water shut-off

Automatic water shut-off customization parameters

Diagnostic Plumbing Tests

Monthly, weekly, hourly water use data

Single device, whole home protection

Connectivity Requirements

Wi-Fi connection

Bluetooth connection (Service Professional Access to Device)

Phone or tablet with iOS 14+, Android 10+

LeakSecure app

Certifications

FCC 15.109 Radiated Emissions and 15.107 Conducted Emissions Class B and IC ICES-003 Issue 7 (October 2020) Class B Host

Integration KB 996369 FCC Part 15.209(a)

/ 15.205 RoHS 2011/65/EU Compliant:

Hazardous Substances

Warranty

1-year limited warranty

Homeowners Guide (Onboarding)

Congratulations on the purchase of your new LeakSecure device! LeakSecure is an advanced leak detection and water conservation ecosystem. The LeakSecure app will prompt you through the onboarding steps but if you need additional assistance, step by step instructions are provided here for completing the process.

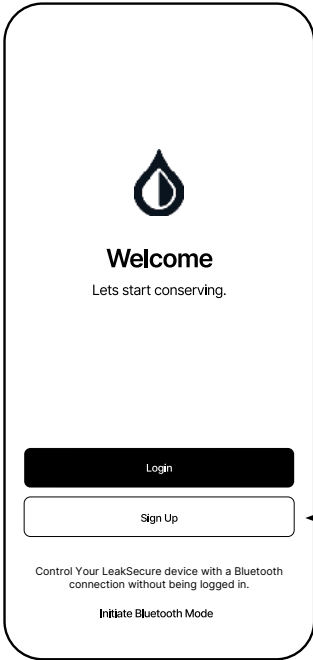

1 Begin by opening the LeakSecure app (if you already have a LeakSecure account, skip to step 3). On the splash screen, tap "Sign Up".

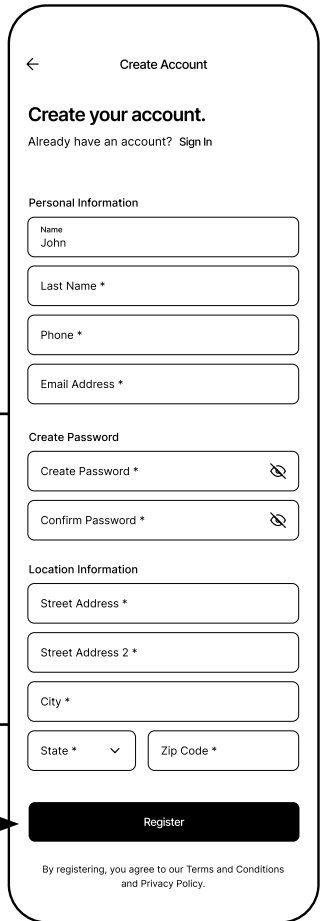

2 Fill all fields on the "Create your account" screen and tap "Register" when finished.

An email will be sent to the email address provided during the sign up process. In the email, check the information to ensure everything looks correct. If so, click "verify" to complete the sign up process.

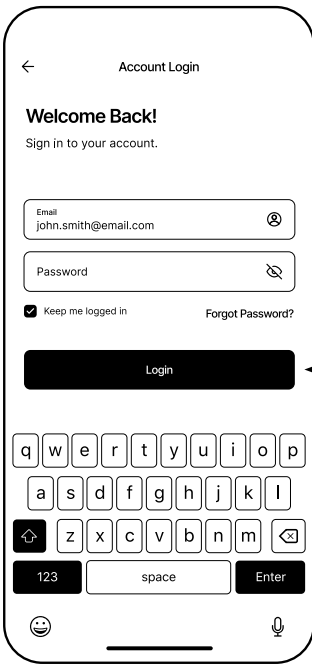

3 From the LeakSecure app, tap “Login”. From the Login screen (Figure 2), enter the email address and password that you chose during the account creation step, then tap “Login”. If you select “Keep me logged in”, you will not have to enter your login information every time you want to access your LeakSecure device.

4 Follow the on-screen prompts to add your first location. This information helps the LeakSecure AI accurately determine when leaks have occurred and is used by the app to provide feedback on your water usage. Be sure that all the information you provide during the location setup is accurate to ensure your LeakSecure device performs optimally.

You should know the following information about your home:

- Location type
- LeakSecure install location
- Address
- Location size (in square feet)
- Number of bathrooms
- Number of floors
- Number of people living at the location
- Plumbing information
- Water cost per gallon

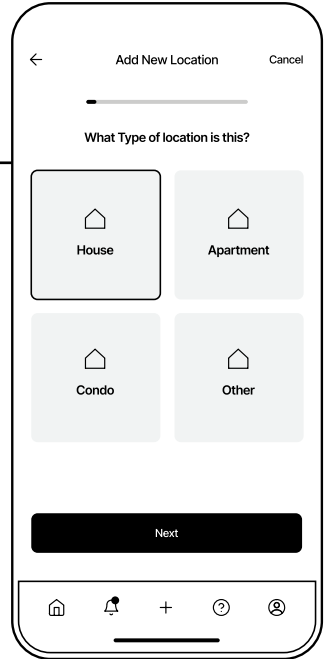

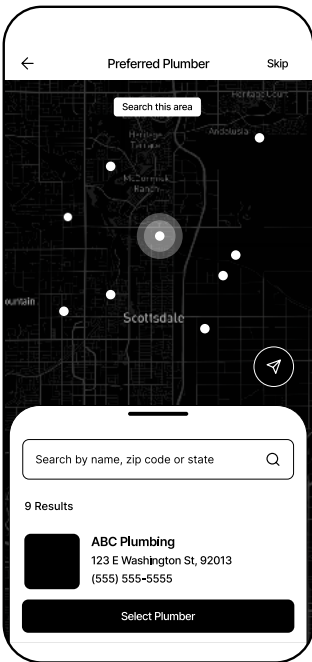

5 The LeakSecure app can send information on your LeakSecure system to your Preferred Plumber. This feature makes the process of troubleshooting leaks or other problems quick and easy.

6 Once you have finished creating a location, tap “Add Device” to pair your LeakSecure device with your account (Figure 4).

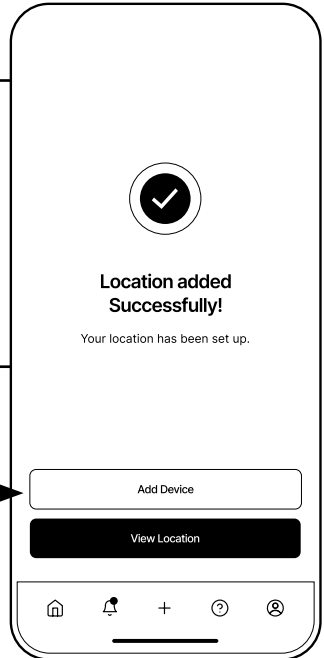

7 Ensure your LeakSecure device is powered on. If device is not powered, verify that the included AC adapter is connected securely to both the LeakSecure device and a working outlet. On the “Add New” screen, select “LeakSecure Valve”

8

Choose the location where you want to add your LeakSecure device. This should be the location you just created in the previous steps (Figure 6).

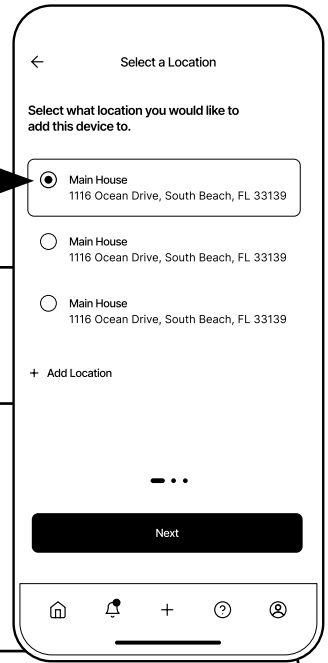

9

On the Network Setup screen (Figure 7), a set of instructions is provided that describes how to enable Bluetooth on your iOS or Android smart phone. Once your phone has Bluetooth enabled, press the "Pair" button on your LeakSecure device and tap "next" on the Network Setup screen.

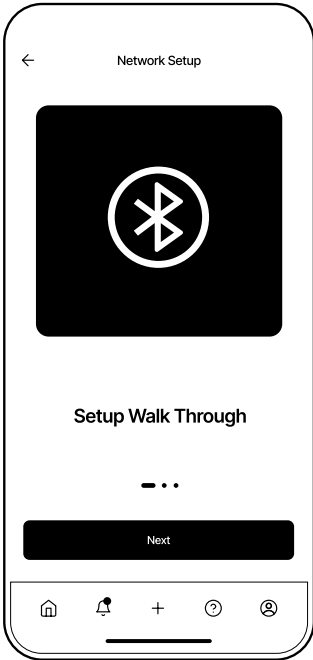

10

Select "LeakSecure Valve" from the list of devices to highlight it, then tap "continue".

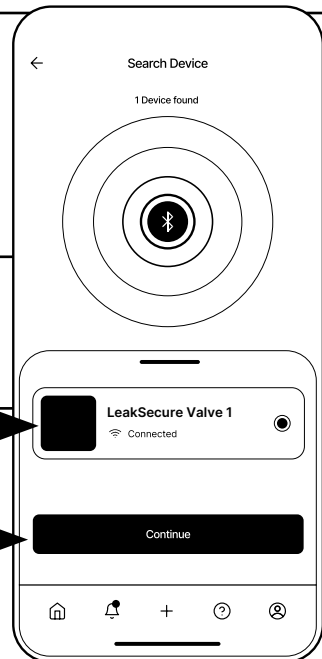

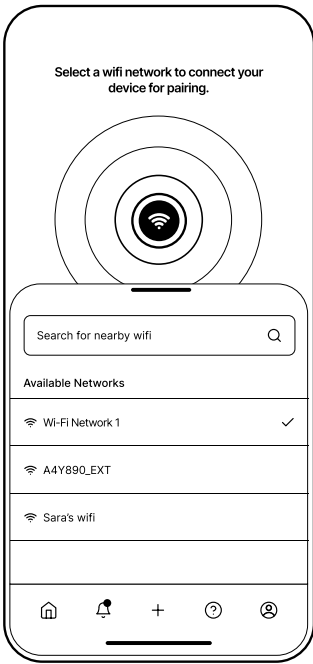

11

Now that your LeakSecure device is paired with your phone via Bluetooth, select that location's Wi-Fi network from the list. To ensure successful pairing, verify that the network signal is strong near where the LeakSecure device is installed.

Once you have selected a network, you will be prompted to enter the network password. Enter the network password, then tap "Join".

12

If the device connects to the network successfully, you will see a message that says "Network Pairing Success!". Tap "Manage Device" to continue

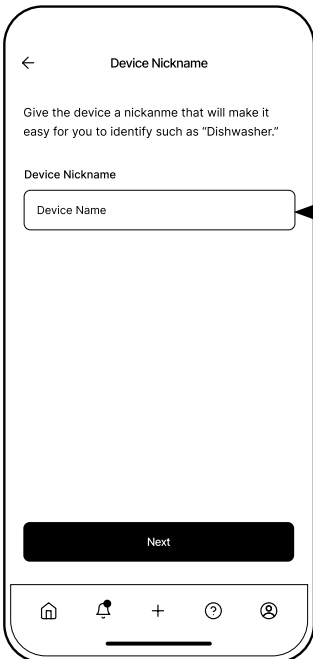
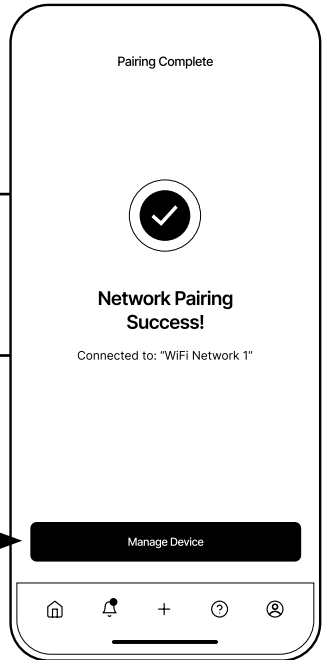

13

Assign your device a nickname by tapping the "Device Name" box. Choose a name that will be helpful to distinguish this device from others in your LeakSecure Ecosystem at this location.

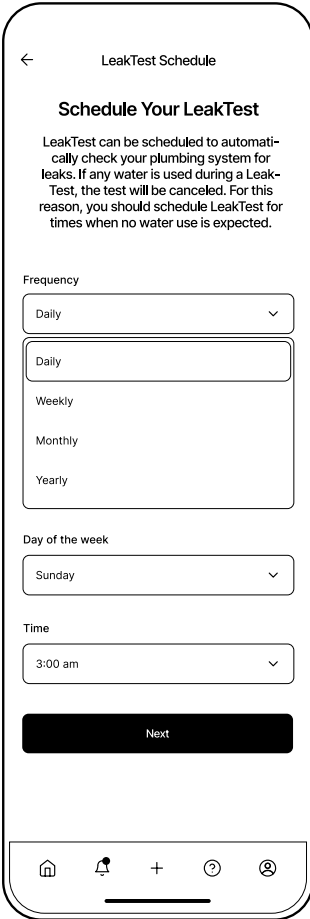

14

Your LeakSecure device supports periodic testing of your plumbing system's integrity using the LeakTest feature. This feature is particularly useful for detecting small leaks or dripping fixtures. When LeakTest runs, the valve on your LeakSecure device will close automatically and monitor the pressure change in your plumbing system for a period of up to 5 minutes.

Running water on your plumbing system during a LeakTest will abort the LeakTest. For this reason, it is recommended to schedule your LeakTest during times when no water use is expected at the location where the LeakSecure device is installed.

By default, LeakTest is scheduled to run daily at 3:00 AM, but this may not be appropriate for your location.

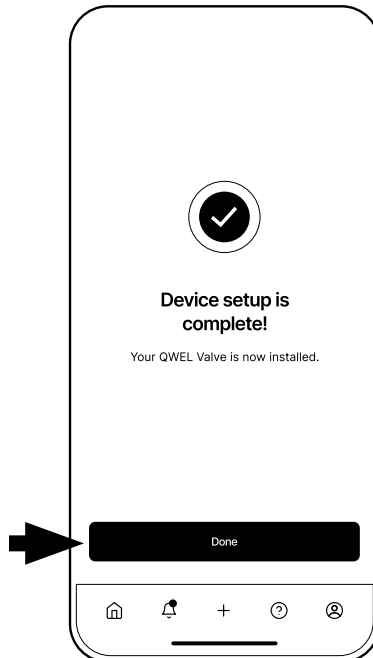

Bluetooth Mode

In situations where a Wi-Fi connection is not available, it is possible to control your LeakSecure device directly using Bluetooth Mode. Your Preferred Plumber may find Bluetooth Mode useful for quickly troubleshooting the LeakSecure hardware. In Bluetooth Mode, controls are restricted to:

- Opening and closing the valve
- Running a LeakTest
- Enabling or disabling the automatic shutoff feature
- Viewing real-time sensor data and device information

To access LeakSecure in Bluetooth mode:

- 1** Ensure your phone has Bluetooth turned on and that your LeakSecure device is powered on.

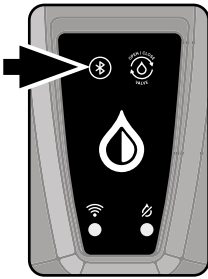

- 2** Press the pairing button on your LeakSecure device.

- 3** Open the LeakSecure app. On the splash screen, tap “Initiate Bluetooth Mode” to look for your LeakSecure device.

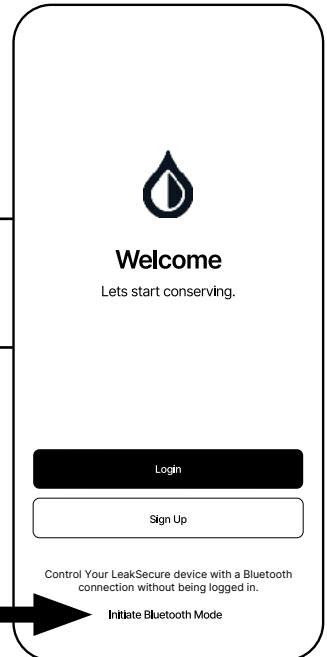

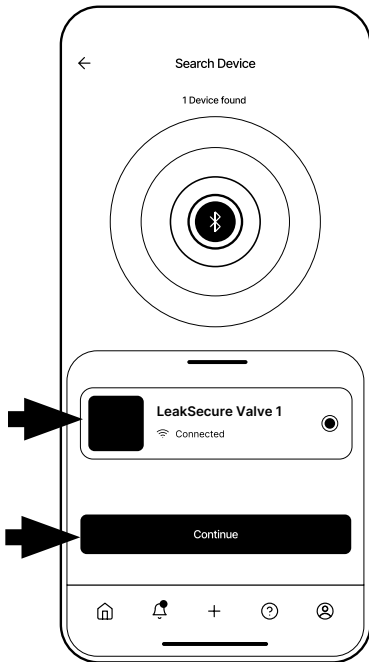

4 Tap the entry for your LeakSecure device. You will see it either as “LeakSecure” or by the name that you chose during the setup process, then tap “Continue”.

5 If the connection was successful, you will see the Bluetooth Mode screen. You can access controls for valve operation and automatic shutoff here.

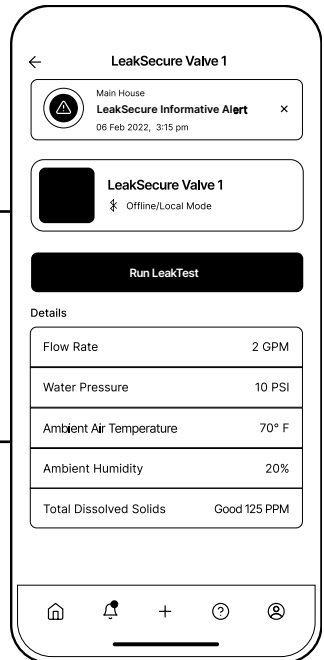

One (1) Year Limited Warranty

What is covered under this limited warranty (including, if applicable, the Supplemental Warranty as defined and set forth below) (the “Limited Warranty”)

Notation Labs, Inc (“LeakSecure”) warrants to the original purchaser of this LeakSecure product that, when properly installed, the product will be free from defects in materials and workmanship under normal conditions of use for a period of one (1) year from the date of installation to the purchaser (the “Limited Warranty Period”).

We reserve the right to change the terms of the Limited Warranty at any time so please review this Limited Warranty every time you place an order or otherwise acquire any LeakSecure product.

What will we do to correct problems

If LeakSecure determines that the product was installed appropriately and has failed or is defective within the scope of this Limited Warranty, LeakSecure will, at its option, either (i) repair or replace, free of charge, any defective LeakSecure product, or (ii) accept the return of the product and refund the money actually paid by the original purchaser for the product. Repair or replacement may be made with a new or refurbished product or component, at LeakSecure’s sole discretion. LeakSecure reserves the right to discontinue any of its products without notice and disclaims any warranty to repair or replace any such discontinued products. In the event that LeakSecure is unable to repair or replace a product (for example, because it has been discontinued) covered by the Limited Warranty, LeakSecure will offer a credit toward the purchase of another LeakSecure product in an amount equal to the purchase price of the product as discounted. If the product or a component incorporated within it is no longer available, LeakSecure may, at its sole discretion, replace the product with a similar product of similar function.

This is your sole and exclusive remedy for breach of this Limited Warranty. This Limited Warranty is transferable from the original purchaser to subsequent owners, but the Warranty Period will not be extended in duration or expanded in coverage for any such transfer.

What is not covered by this Limited Warranty

In order for this Limited Warranty to be in effect, the LeakSecure product must be: (i) installed, maintained, repaired and operated in accordance with the instructions provided by LeakSecure; (ii) installed in an end-use environment as intended for the product; and (iii) installed in accordance with then-applicable building, mechanical, plumbing, electrical, or other applicable code requirements.

Without limiting the foregoing, this Limited Warranty does not cover and will be voided if LeakSecure determines that any of the following have occurred: (i) the product was not installed in accordance with the terms of LeakSecure’s Installation Guide or other written instructions provided by LeakSecure; (ii) the product has been altered or tampered with in any way or improperly handled or maintained; (iii) the product has been exposed to temperatures and/or pressures that exceed the limitations for the product, exposed to highly corrosive atmospheric conditions or subjected to abnormal physical or electrical stress; (iv) the product was installed, handled, or stored not in accordance with instructions provided by LeakSecure; or (v) the product was combined with any non-LeakSecure hardware products. This Limited Warranty does not cover data loss related to the LeakSecure hardware product regardless of the nature or basis of the loss. Products installed on anything other than potable water service lines shall not be covered by this Limited Warranty (for example, irrigation lines or well systems). Unauthorized use of the product or software can impair the product’s performance and may invalidate this Limited Warranty.

This Limited Warranty does not protect against, and any liability for losses related to any of the

following are hereby expressly excluded; acts of God such as flood, lightning, earthquake, war, vandalism, theft, and does not protect against losses due to normal-use wear and tear, erosion, depletion, obsolescence, abuse, damage due to low-voltage disturbances (i.e., brownouts or sags), non-authorized program, inadequate connectivity of the LeakSecure hardware product to wi-fi networks or otherwise, wi-fi throughput below required levels, or system equipment modification.

In addition, LeakSecure does not give any warranty: (i) in relation to software or services provided or made available by LeakSecure with the product, whether factory loaded on the product, contained on media accompanying the product, or downloadable in connection with the product; (ii) in relation to any third-party software or service offerings which may be included in, accessible by, or bundled with the product; (iii) that the operation of the LeakSecure product, software, or services will be uninterrupted or error free; (iv) that the LeakSecure product, software or services, or any equipment, system or network on which the product, software or services are used, will be free of vulnerability to intrusion or attack; or (v) as to the continued availability of a third party's service which this product's use or operation may require.

Warranty replacement or deposits may be subject to a restocking fee of up to 20% of the purchase price, plus any applicable sales tax, unless the product is defective or the return is a result of a LeakSecure error. Details for any deduction will be shown on your confirmation email for the return.

30-day return policy

If you are the original purchaser of the product, purchased through LeakSecure directly, and you wish to return the product for any reason, you may return it in its original condition within thirty (30) days of the original purchase and receive a full refund. If the product was installed or has been used in any way then it is not eligible for the refund.

Your refund will be initiated once we receive and inspect your return. Please allow us up to 15 business days to complete inspection. Once completed, you will receive email confirmation of your refund.

LeakSecure may deny refund or exchange for any returns that have been tampered with, have missing parts, have been misrepresented and/or are not received and inspected by our warehouse.

Original shipping and handling charges may not be refunded.

The product should be shipped in an outer box for protection and contain a note with the Order number, contact information, and reason for the return.

We can only issue refunds back to the original form of payment. To receive a complete refund, all items from the original purchase must be returned.

If you financed your purchase, refunds will not include any interest due on the loan or any of the non-refundable amounts described above, and you will remain responsible for the performance of your financing agreement.

Return refunds may be subject to a restocking fee of up to 15% of the purchase price, plus any applicable sales tax, unless the product is defective or the return is a result of a LeakSecure error. Details for any deduction will be shown on your confirmation email for the return.

If you have met all the requirements of 30-day return policy and wish to return your LeakSecure product(s) then please contact LeakSecure at store@Leaksecure.com for instructions on returning your device. Please include Order number, complete contact information and the reason for the return. LeakSecure will not accept returns if it is outside of the 30-day policy.

How to get service for your LeakSecure product warranty

1. Contact LeakSecure by emailing support@Leaksecure.com within 5 days of recognizing a defective LeakSecure product within the Limited Warranty Period

IMPORTANT: When submitting a claim under this Limited Warranty be prepared to provide the following information:

The part number of the LeakSecure product (printed physically on the device).
MAC address (printed on the label attached to the blue customer quick start guide).
Copy of the original receipt

2. A LeakSecure customer service representative will provide the information on how to proceed with your claim.

LeakSecure reserve the right to review the damaged LeakSecure product. The damaged product must remain available for inspection until the claim is finalized. Whenever claims are settled, LeakSecure reserve the right to be subrogated under any existing insurance policies the purchaser may have.

Any product that has either been repaired or replaced under this limited warranty will be covered by the terms of this limited warranty for the longer of (a) ninety (90) days from the date of installation of the repaired product or replacement product, or (b) the remainder of the Limited Warranty Period.

LeakSecure will not provide any warranty coverage unless your claim is made in compliance with all terms of this Limited Warranty as set forth above.

Exclusions and disclaimers under this Limited Warranty

This Limited Warranty gives you specific legal rights, and you may also have other rights, which may vary from state to state. Some states do not allow the exclusion or limitation of incidental, consequential, or other damages, so the above limitations may not apply to you. The terms of this Limited Warranty will apply to the extent permitted by applicable law. For a full description of your legal rights you should refer to the laws applicable in your jurisdiction and you may wish to contact a relevant consumer advisory service.

EXCEPT AS PROVIDED IN THIS LIMITED WARRANTY AND TO THE MAXIMUM EXTENT PERMITTED BY APPLICABLE LAW, IN NO EVENT SHALL LeakSecure, OR THEIR AFFILIATES, OR THEIR RESPECTIVE OFFICERS, DIRECTORS, EMPLOYEES, LICENSORS AND ASSIGNS, BE LIABLE FOR ANY DIRECT, INDIRECT, EXEMPLARY, PUNITIVE, SPECIAL, INCIDENTAL, OR CONSEQUENTIAL DAMAGES WHATSOEVER (INCLUDING BUT NOT LIMITED TO DAMAGES FOR LOSS OF PROFITS OR REVENUE, FOR DAMAGE TO REAL OR PERSONAL PROPERTY, FOR BUSINESS INTERRUPTION, FOR PERSONAL INJURY, FOR LOSS OF PRIVACY, FOR LOSS OF ABILITY TO USE ANY THIRD-PARTY PRODUCTS OR SERVICES, FOR FAILURE TO MEET ANY DUTY INCLUDING OF GOOD FAITH OR OF REASONABLE CARE, FOR NEGLIGENCE, AND/ OR FOR ANY OTHER PECUNIARY OR OTHER LOSS WHATSOEVER), REGARDLESS OF THE THEORY OF LIABILITY (CONTRACT, TORT, OR OTHERWISE), ARISING OUT OF OR IN ANY WAY RELATED TO THE USE OF OR INABILITY TO USE THE PRODUCT, EVEN IF LeakSecure, OR THEIR AFFILIATES HAVE BEEN ADVISED OF THE POSSIBILITY OF SUCH DAMAGES. THIS LIMITATION IS CUMULATIVE AND WILL NOT BE INCREASED BY THE EXISTENCE OF MORE THAN ONE INCIDENT OR CLAIM. THE FOREGOING LIMITATIONS WILL APPLY EVEN IF ANY WARRANTY OR REMEDY PROVIDED FAILS OF ITS ESSENTIAL PURPOSE. NOTHING HEREIN SHALL LIMIT THE LIABILITY OF LeakSecure IN RELATION TO DEATH OR BODILY INJURIES.

THE WARRANTIES AND REMEDIES SET OUT IN THIS LIMITED WARRANTY ARE EXCLUSIVE AND, TO THE EXTENT PERMITTED BY LAW, IN LIEU OF ALL OTHERS, WHETHER ORAL OR WRITTEN, EXPRESS OR IMPLIED.

IN THOSE JURISDICTIONS WHERE IT CAN LAWFULLY DO SO, AND TO THE MAXIMUM EXTENT PERMITTED BY APPLICABLE LAW, LeakSecure AND THEIR AFFILIATES HEREBY DISCLAIM AND EXCLUDE ALL OTHER WARRANTIES, EXPRESS, STATUTORY, OR IMPLIED, INCLUDING, BUT NOT LIMITED TO, IMPLIED WARRANTIES OF MERCHANTABILITY, ACCEPTABILITY, SATISFACTORY QUALITY, NON-INFRINGEMENT, TITLE, FITNESS FOR A PARTICULAR PURPOSE, LOSS OF OR DAMAGE TO DATA, LACK OF VIRUSES OR FREE FROM VIRUS OR MALWARE ATTACK, SECURITY, PERFORMANCE, LACK OF NEGLIGENCE, WORKMANLIKE EFFORT, QUIET ENJOYMENT, THAT

THE FUNCTIONS CONTAINED IN THE PRODUCT WILL MEET YOUR REQUIREMENTS, OR THAT DEFECTS IN THE PRODUCT WILL BE CORRECTED, OR THAT YOUR USE OF THE PRODUCT WILL GENERATE ACCURATE, RELIABLE, TIMELY RESULTS, INFORMATION, MATERIAL, OR DATA. THE ONLINE SERVICES INTENDED TO OPERATE WITH THE LeakSecure PRODUCTS PROVIDE USERS WITH CERTAIN INFORMATION. ALL SUCH INFORMATION IS PROVIDED "AS IS" AND "AS AVAILABLE". LeakSecure DOES NOT WARRANT OR GUARANTEE THAT SUCH INFORMATION WILL BE AVAILABLE, ACCURATE, OR RELIABLE OR THAT USE OF SUCH INFORMATION, SUCH ONLINE SERVICES, OR LeakSecure PRODUCTS WILL FULLY PROTECT REAL PROPERTY FROM WATER DAMAGE. NO ORAL OR WRITTEN INFORMATION OR ADVICE GIVEN BY LeakSecure, OR A DEALER, RESELLER, AGENT, REPRESENTATIVE, OR AFFILIATE OF LeakSecure SHALL CREATE A WARRANTY. TO THE EXTENT WARRANTIES CANNOT BE DISCLAIMED OR EXCLUDED, THEY ARE LIMITED TO THE DURATION OF THE RELEVANT EXPRESS WARRANTY PERIOD.

Some states do not allow limitations on how long an implied warranty lasts, so the above limitations may not apply to you.

Limitations on liability under this Limited Warranty

TO THE MAXIMUM EXTENT PERMITTED BY APPLICABLE LAW, THIS LIMITATION SHALL APPLY TO ANY AND ALL DAMAGES, REGARDLESS OF THE LEGAL THEORY ON WHICH THEY ARE ASSERTED (INCLUDING, WITHOUT LIMITATION, CONTRACT, BREACH OF CONTRACT OR TORT), AND REGARDLESS OF WHETHER LeakSecure HAS BEEN ADVISED OF THE POSSIBILITY OF

LeakSecure Privacy Policy

Notation Labs, Inc. ("Notation") provides LeakSecure™ devices to homeowners ("Homeowners") to monitor the flow of water through their main water line ("Data") for the purpose of detecting and preventing water leaks inside the home ("LeakSecure Device"). Homeowners access their Data with the LeakSecure iOS and Android app ("LeakSecure App"). Homeowners download the LeakSecure App onto their phones or other handheld devices, and register their LeakSecure Device with Notation through the LeakSecure App. The LeakSecure App is connected to AWS cloud servers, and the servers make the Data available through the LeakSecure App to Homeowners. The Data is also shared with the plumbing professional service providers who installed the LeakSecure Device ("Installers"). Each Installer has its own account and dashboard that presents the Data of its Homeowner customers. Notation provides Homeowners and Installers with customizable alerts and the ability to automatically and remotely shut off water. This Privacy Policy does not cover or affect the terms of any agreement between Homeowners and Installers, or information collected on the website at www.Leaksecure.com.

This Privacy Policy explains how we, Notation, collect, use, store, and share personal information collected by the LeakSecure Device and the LeakSecure App. It is incorporated by reference into the LeakSecure End User License Agreement (EULA) which is binding on all users of the LeakSecure App. By using the LeakSecure App, you consent to the collection and use of your personal information in accordance with this Privacy Policy. If you do not agree to the terms of this Privacy Policy or the LeakSecure EULA, please do not use the LeakSecure App. If we make material changes to our Privacy Policy, we will advise you of the changes through postings on the LeakSecure App.

What does this Privacy Policy Cover?

Personally identifiable information is information that is not publicly available and that identifies, relates to, or describes you specifically (e.g., your name, address, e-mail address, or phone

number), or is reasonably capable of being associated with you or your household (“Personally Identifiable Information” or “PII”).

What PII do we collect, why, and how is it used and shared?

Category of Personal Information Collected

Source

Purpose for Collection

Categories of Recipients

Contact information: Name, address, email addresses, mobile and other telephone numbers\

Provided by Homeowners when they register their LeakSecure Device on the LeakSecure App

To provide Data and alerts to Homeowners and Installers

To provide related services

To facilitate water shut off

To verify the identity of the Homeowner

Insurance companies, at the request of the Homeowner, to verify use of the LeakSecure Device

Browsing information: Page views, IP addresses, device identifier of the device on which you are using the LeakSecure App, session identifiers, location information, and other statistics in the form of logs to track user activities

This information is necessary for our servers to know where to send back your page requests

To understand how Customers are using the LeakSecure App

To enhance the technical performance of the LeakSecure App

To protect the security and integrity of the LeakSecure App, and our business, such as preventing fraud, hacking, and other criminal activity or to meet legal obligations

Service providers who help Notation with fraud protection and analytics

Payment information: name, card issuer and card type, credit or debit card number, expiration date, CVV code, and billing address

From the Homeowner or the Installer - which is directly collected by our payment processors.

To identify LeakSecure Device purchases and purchases of related services

Service providers who process payments for us. They are prohibited from using PII for any other purposes and are contractually required to comply with all applicable laws and requirements, including the Payment Card Industry Data Security standards

Suspected crime information: Details of your identity, name and address, suspected or alleged fraud or other criminal behavior

From crime and fraud prevention agencies, witnesses, and law enforcement

To respond to subpoenas, search warrants, judicial proceedings, court orders, legal process, or other law enforcement measures, to establish or exercise our legal rights, or to defend against legal claims

To investigate, prevent, or take action regarding alleged or actual illegal activities, violations of the LeakSecure EULA, Privacy Policy, or as otherwise required by law

Law enforcement and other governmental authorities in accordance with applicable law, and our professional advisors

Business Transactions: If we or the LeakSecure business is acquired, or we otherwise transfer any assets (including due to a sale in connection with a bankruptcy), we may provide your PII to the purchaser for use by such purchaser, subject to the terms of this Privacy Policy.

Aggregate Information: Occasionally, we may share, sell or rent aggregated, de-identified market research data with third party partners and vendors.

Customer Communication

Our customer service representatives may use your telephone numbers and email addresses to notify you of the status of your LeakSecure Device and for other purposes, such as quality assurance, product safety, and customer service matters.

Security Information

We use industry standard encryption technologies, such as 2048-bit SSL Secure Sockets Layer with TLS Encryption, when transferring and receiving PII and Data. PII and Data is stored using industry standard AES-256 encryption. However, no commercial method of information transfer over the Internet or electronic data storage is known to be 100% secure. As a result, we cannot guarantee the absolute security of that information during its transmission or its storage in our systems.

5. The LeakSecure App is Provided in the US under US Law
We do not yet make the LeakSecure App available outside of the U.S. US law governs our provision of the LeakSecure App and your use of it.

Children's Privacy

The LeakSecure App is not designed for, or directed at, anyone eighteen (18) years of age or younger. It is not our policy to intentionally collect or maintain information about anyone under the age of eighteen (18). No one under the age of eighteen (18) is permitted to submit any personal information to Notation. If you learn that anyone under the age of eighteen (18) has submitted personal information to Notation, please contact us immediately at privacy@Leaksecure.com.

Opting Out of Data Collection; Information Correction; Data Retained

You may opt out of information collection at any time by uninstalling the LeakSecure Device from your home, uninstalling the LeakSecure App from your phone or other handheld device, and/or by deactivating any account you may have created by emailing us at privacy@Leaksecure.com. You can correct or update your PII by re-registering, updating your profile, or by contacting us by email at privacy@Leaksecure.com or sending a written request to the address set forth in Section 8 below. However, we will maintain copies of your information to the extent retained as part of our standard backup and archive process, and as required by applicable law. These procedures will not remove or update any information that you or we have provided to Installers or insurers.

Contact Us

If there are any questions regarding this Privacy Policy, please contact us using the information below:

LeakSecure
Notation Labs, Inc.
c/o Privacy Policy
15900 N. 78th Street, Suite 200
Scottsdale, AZ 85260

privacy@Leaksecure.com



LEAKSECURE

Smart Leak Detection+Automatic Shutoff



CONTROL YOUR WATER[®]



UNITED
Water Softeners